



杭州天裕光能科技有限公司

HANGZHOU AMPLESUN SOLAR TECHNOLOGY CO. LTD.

# Installation Manual

Photovoltaic Module ASF100

AST-3T4-052

Rev. 3



## 1 INTRODUCTION

This manual includes information about the safe use of thin film solar module ASF100 and ASF90, including mechanical installation, connection wiring as well as important information about connecting to the power inverter. They are only for specialists who are familiar with the installation due to their vocational qualification. The tasks described in these instructions may only be carried out by qualified experts. If you do not possess appropriate qualifications, you are not permitted to carry out the work described.

Information and suggestions in this manual are based on knowledge and experience of Hangzhou Amplesun Solar Technology Co. Ltd. (abbreviated as “AST” in the following text). And AST reserves the right to make changes to the product, specifications, or to the manual without prior notice.

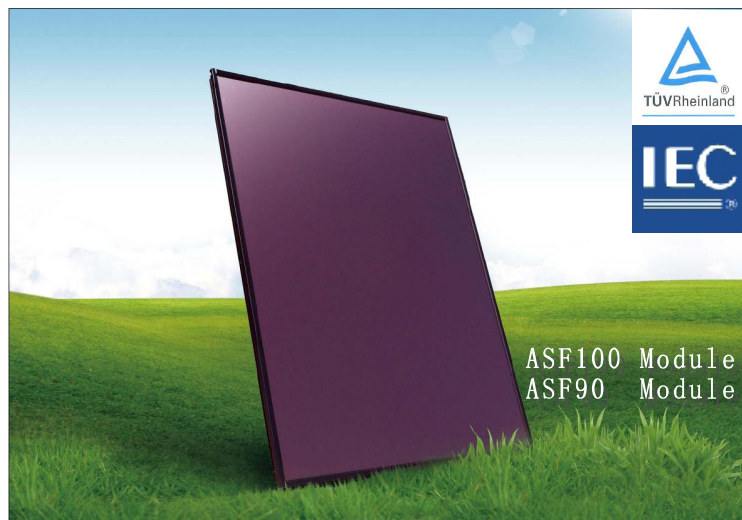

## 2 APPLICATIONS

AST thin film PV modules are a highly reliable, virtually maintenance-free direct current (DC) power source, designed to operate most efficiently in sunlight. ASF series modules PV modules fulfill the requirements of Application Class A (Safety Class II), ideal to for solar farms, remote homes, recreational vehicles, water pumps, telecommunication systems and many other applications either with or without the use of storage batteries.

## 3 GENERAL SAFETY INSTRUCTION

- 1) The thin film solar modules must be assembled and operated according to latest available procedures. When assembling, it is vital to observe and to adhere to the respective national health and safety at work. Special attention should be paid to regulations relating to work on a roof.

# AmpleSun Solar

- 2) Danger of falling exists when working on the roof and climbing up and down ladders. Ensure that you observe the accident prevention regulations and use appropriate safety rails.
- 3) Unauthorized persons may not carry out such work described in this manual.
- 4) Keep children away from the dangerous zone.
- 5) Warn all people who are close to the endangered area and those in the house.
- 6) The solar modules are electricity supply points with the respective potential dangers. Even at low luminous intensity, the full no-load voltage must be calculated.
- 7) Artificially concentrated sunlight shall not be directed to the module. Permanent damage to amorphous silicon film may occur as a focused sunlight may overheat the film.
- 8) Beware of electrical shock and short-circuit when module is irradiated.
- 9) Do not disassemble modules, which could cause fire, electrical shock and injury.
- 10) Do not wear metallic jewelry, which could cause of electric shock during installation.
- 11) Handle cables with insulating gloves, when the module is irradiated.
- 12) Incorrect installation or commissioning may lead to damages of equipment and place people at risk.
- 13) Never connect the modules directly to the electrical loads such as motors, since the variation of output power may cause damage to them.
- 14) To isolate the module from incident light, cover the surface of the module with cloth or other suitable sufficiently opaque materials.
- 15) Do not expose modules to artificially concentrated sunlight.
- 16) Do not step on the modules.
- 17) Ground the module by electrical connection from the aluminum frames of the module to ground.
- 18) Product should be installed and maintained by qualified personnel.
- 19) Keep the cells out of the shadow as possible, which could cause hot spots on the module.
- 20) Do not install the modules in the area which has very heavy snow in the winter.
- 21) For safety reasons, do not open the junction box.
- 22) Protect the solar power modules at the front and the back against scratching and other damages.
- 23) Protect the module cables against mechanical stress during transport and installation.
- 24) Before installing, check the junction box, cables and socket connectors for damages.
- 25) Protect plug contacts against soiling.
- 26) Do not make any plug connections using soiled plug contacts.
- 27) Never disconnect or connect the socket connections whilst under electrical load!
- 28) Never install damaged solar power modules.
- 29) The solar power modules and, in particular the socket connectors plus tools, must be dry during installation.

30) Do not store the solar power modules unsecured.

## 4 MODULE STRUCTURE AND CHARACTERISTICS

### 4.1) Mechanical Structure

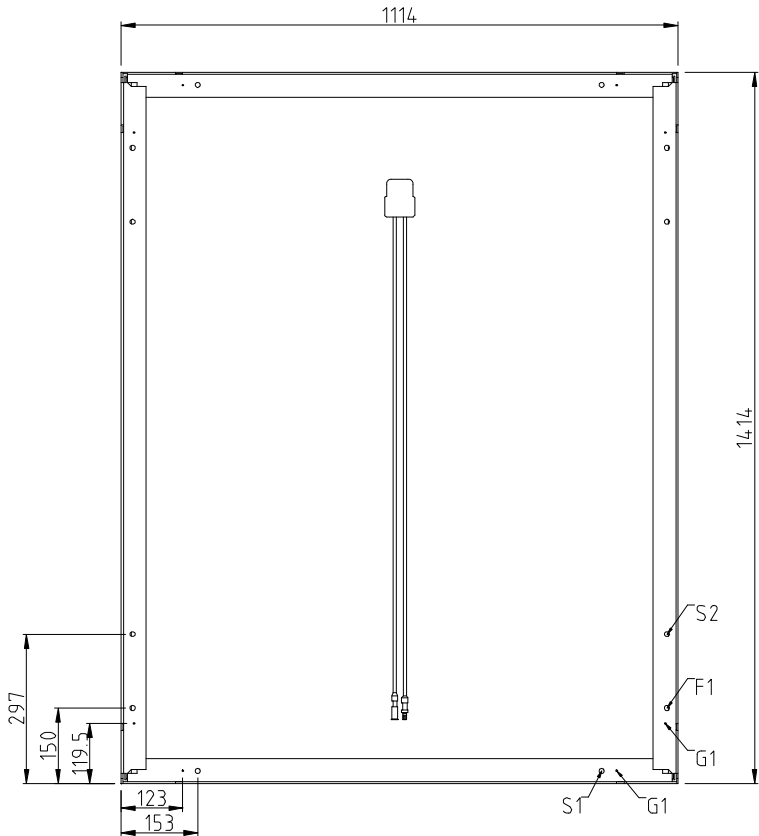

Fig. 1 Module dimensions (Backside)

F1: mounting holes

The modules may be mounted with these mounting holes

G1: grounding holes

The modules may be grounded with eight grounding holes

S1, S2: service holes

“S1” and “S2” may be used for mounting and grounding purpose, however, the customer shall notify AST in advance and ask for proper advice in case using those holes.

### 4.2) Module Performance Characteristics

#### 4.2.1 Electrical Performance of ASF100, ASF90 at STC

Electrical data below represents stabilized values at Standard Test Conditions (STC)

# AmpleSun Solar

Model		ASF100	ASF90
Maximum power:	P <sub>max</sub> (W)	100	90
Maximum power voltage:	V <sub>mpp</sub> (V)	77	73
Maximum power current:	I <sub>mpp</sub> (A)	1.29	1.24
Open circuit voltage:	V <sub>oc</sub> (V)	99	98
Short circuit current:	I <sub>sc</sub> (A)	1.65	1.59
Maximum system voltage:	V <sub>sys</sub> (V)	1000	1000

- 1) Maximum power may vary by  $\pm 5\%$  and other electrical data may vary by  $\pm 10\%$ .
- 2) The electrical characteristics are within  $\pm 10\%$  of the indicated values of I<sub>sc</sub> and V<sub>oc</sub> under Standard Test Conditions (STC: irradiance of 100mW/cm<sup>2</sup>, AM1.5 Spectrum, and cell temperature of 25°C (77°F)).
- 3) Under normal conditions, a photovoltaic module may experience conditions that produce more current and/or voltage than reported at Standard Test Conditions. Accordingly, the values of I<sub>sc</sub> and V<sub>oc</sub> marked on this module should be multiplied by a factor of 1.25 when determining component voltage ratings, conductor capacities, fuse sizes and size of controls connected to the module output. Refer to local Electric Code for an additional multiplying factor of e.g. 125 percent (80 percent of rating) wherever applicable.

## 4.2.2 Electrical Performance of ASF100, ASF90 at NOCT

Electrical data below represents stabilized values at Nominal Operating Cell Temperature (NOCT):

Model		ASF100	ASF90
Nominal Operating Cell Temp:	NOCT (°C)	43.2	43.2
Maximum power:	P <sub>max</sub> (W)	79	71
Maximum power voltage:	V <sub>mpp</sub> (V)	76	74
Maximum power current:	I <sub>mpp</sub> (A)	1.04	0.96
Open circuit voltage:	V <sub>oc</sub> (V)	96	94
Short circuit current:	I <sub>sc</sub> (A)	1.25	1.19
Maximum system voltage:	V <sub>sys</sub> (V)	1000	1000

- 1) Maximum power may vary by  $\pm 5\%$  and other electrical data may vary by  $\pm 10\%$ .
- 2) The electrical characteristics are within  $\pm 10\%$  of the indicated values of I<sub>sc</sub> and V<sub>oc</sub> under Nominal Operating Cell Temperature (The estimated temperature of a solar PV module when it is operating under 800 W/m<sup>2</sup> irradiance, 20°C ambient temperature and a wind speed of 1 meter per second).
- 3) Under normal conditions, a photovoltaic module may experience conditions that produce more current and/or voltage than reported at NOCT. Accordingly, the values of I<sub>sc</sub> and V<sub>oc</sub> marked on this module should be multiplied by a factor of 1.25 when determining component voltage ratings, conductor capacities, fuse sizes and size of controls connected to the module output. Refer to local Electric Code for an additional multiplying factor of e.g. 125 percent (80 percent of rating) wherever applicable.

## 4.2.3 Conversion efficiency as a function of irradiance

For reference only, the following data shows a typical change in conversion efficiency

with decreasing irradiance. The result may vary from module to module.

Model:	ASF100*		
Irradiance (W/m <sup>2</sup> ):	1000	800	200
Conversion Efficiency (%)	6.91	6.81	5.67
Percentage Change in conversion efficiency	100%	98%	82%

\*Measurement temperature: 25°C

#### 4.2.4 Mechanical Data of ASF100 and ASF90

Dimension[mm]	L1,414×W1,114×T37.5
Weight [Kg]	21
Dimension of connection box	L75×W60×T16.5
Resin used for connection box	Flame resistant UL94-V0/5VA
IP rating of connection box	IP65
Connector	MC PV-KBT3/KST3 or MC equivalent
Cable length [mm]	1,000
Cable size [mm <sup>2</sup> ]	2.5

#### Temperature Coefficients of ASF\*

Maximum power [W]	-0.20%/°C
Maximum power voltage [V]	-0.32%/°C
Maximum power current [A]	+0.14%/°C
Open circuit voltage [V]	-0.33%/°C
Short circuit current [A]	+0.09%/°C

\*The temperature coefficients listed here were measured in the vicinity of STC, extreme operating temperatures the coefficients may vary.

#### Installation limits of ASF

Maximum System Voltage [V]	1000
Module operating temperature	- 40°C to +85°C
Maximum load	2,400N/m <sup>2</sup> or 245 Kg/m <sup>2</sup>

#### 4.2.5 Characteristic Curves ASF100

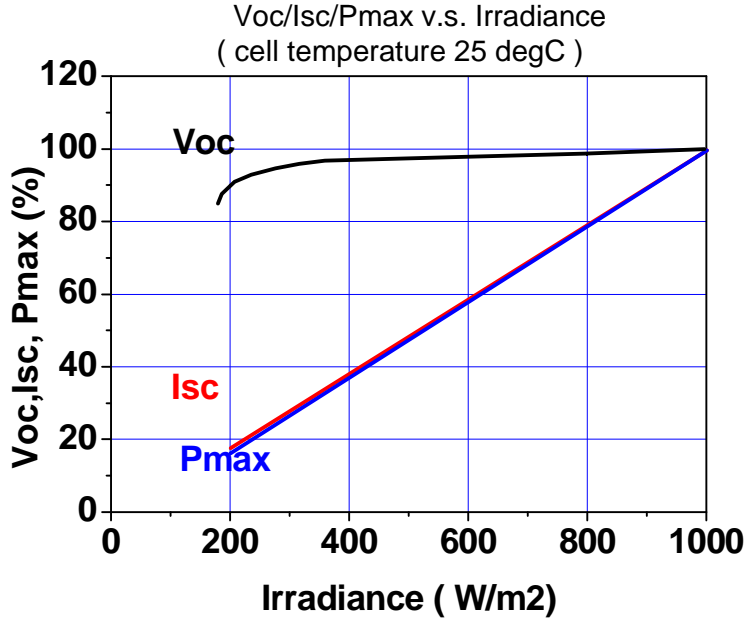
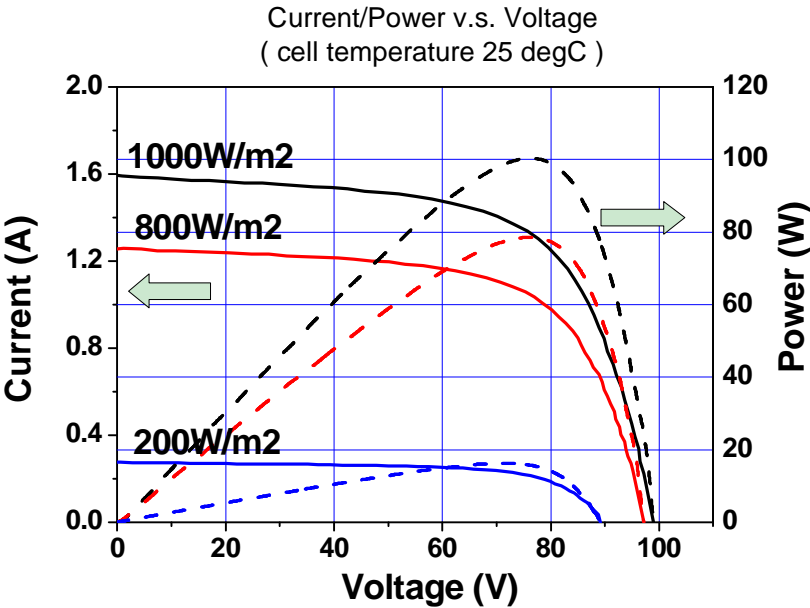

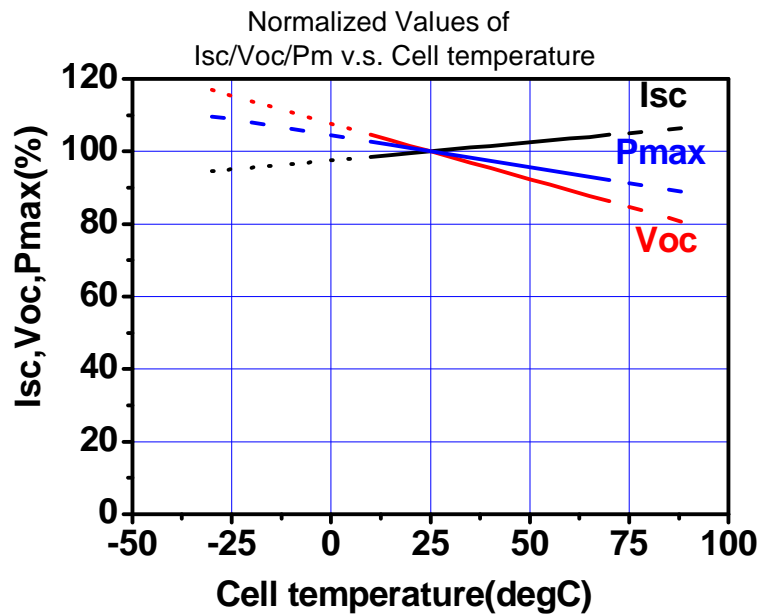

#### 4.3) Materials/Parts used in the modules

- 1) Solar cell type: amorphous silicon deposited by PECVD technology;
- 2) Front cover: 4mm-thick low iron TCO glass;
- 3) Backsheet: laminated PET/Aluminum/PET sheet or equivalent;
- 4) Module junction box: low-profile thin film solar panel junction box, e.g. Onamba PVU-B62 type or equivalent;
- 5) Frame: 6061A aluminum alloy;
- 6) Junction box potting: Two-component resin e.g. PPE/PPO Flame and UV-radiation resistant;
- 7) EVA: Solar EVA by Mitsui Chemicals Fabro or equivalents

## 5 MECHANICAL INSTALLATION

### 5.1) Installation tips

- 1) In order to ensure sufficient self-cleaning of the solar module, the angle of inclination should be at least 10°. At the same time, allow for local conditions (rain quantity, formation of dust etc.).
- 2) The solar modules should be installed in a manner which prevents shadowing effects (also partial shading). An ideal installation is with no shading effects at all times of year, all day long.
- 3) Ensure that the back of the module is well vented.
- 4) For a non-integral module or panel, the assembly is to be mounted over a fire resistant roof covering rated for the application.
- 5) A slope of 5 in/ft (127mm/305mm) is required to maintain a fire Class rating.
- 6) Artificially concentrating the sunlight on the module surface using mirrors or lenses is not permitted as this can increase the temperature of the module to a dangerous state.

- 7) Do not tread on the solar power modules.
- 8) Do not touch solar power modules, frames and connections.
- 9) Do not drop anything on the solar power modules.
- 10) Do not fasten anything to the cables.
- 11) Do not loosen connections under any circumstances whatsoever.
- 12) Never split cables.
- 13) Install the module within the following conditions:
  - a). Ambient temperature: -20°C to 40°C
  - b). Operating temperature: -20°C to 85°C
  - c). Allowable pressure: 2400Pa
- 14) Water resistance/damage: PV modules shall not be immersed in water and shall not be continually exposed to water from a sprinkler, fountain, etc.
- 15) PV module shall not be installed in corrosive area like:
  - a). Salty area: area within 500m from a body of salt water and/or area where salty wind hit directly, or
  - b). Sulfurous area: area near sulfurous volcano and sulfurous spring.

## 5.2) Mounting method

PV modules can be mounted on ground, roof, and pole by using bolts. In most installations a clearance of 5 mm between modules is necessary to accommodate thermal expansion. For proper operation and to avoid damage from condensation, the PV module requires an adequate flow of air across the rear surface. While installing PV modules, ensure sufficient distance between the rear of PV modules and the mounting surface. In case of on-ground installation, be sure to leave sufficient distance between PV modules and the ground to avoid module sopping in water or snow.

## 5.3) Mounting Holes

The PV module has total 12 of  $\Phi 10$  mm holes in its frame for mounting purpose. PV modules may be fastened to a support by using bolt holes that are at the bottom of the frame with stainless steel M8 bolts, washers, spring washers, and nuts (Fig. 2). Do not damage the rear surface of PV modules while fastening PV modules by bolts.

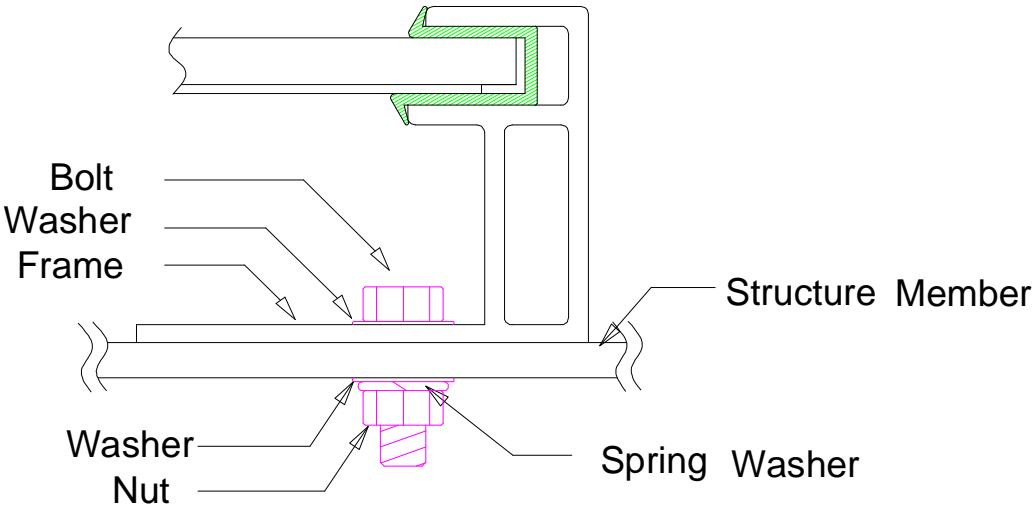

Fig. 2 Mounting Holes

5.4) Mounting Structure

PV modules may be mounted using bolts on the long edges of the PV module, which perpendicular (Fig. 3) or parallel to array rails (Fig. 4). PV modules must be supported along the length of the long edges. The array rails must support the bottom of the modules and must be continuous pieces (no breaks in the rail).

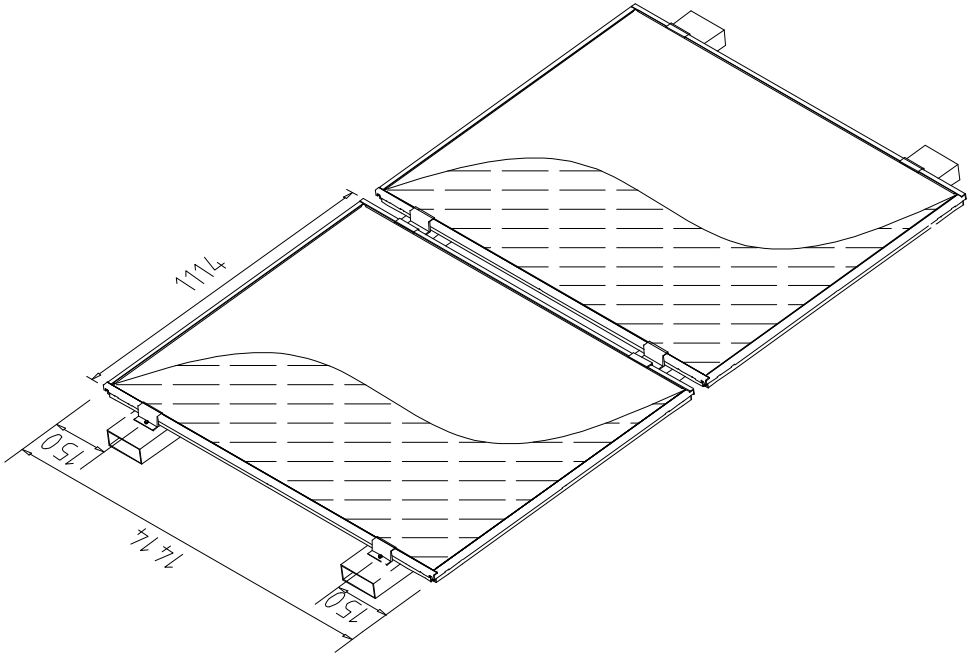

Fig. 3 Mounting structure(perpendicular array rails)

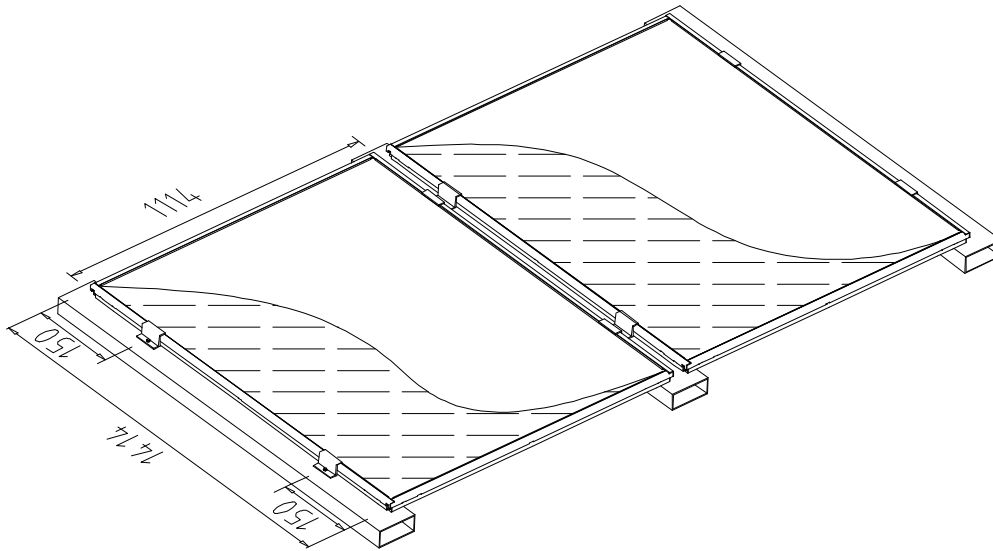

Fig. 4 Mounting structure(parallel array rails)

## 6 ELECTRICAL INSTALLATION

### 6.1) Wiring General

- 1) To maintain the applicability of TÜV listing, use TÜV approved solar copper wire, rated sunlight resistant and 90°C, for all wiring exposed to the weather. The wire may be stranded or single conductor. The minimum wire size is 14 AWG (2.5 mm<sup>2</sup>)
- 2) Each PV module has two sunlight resistant output cables, and each is terminated with MC™ compatible connector. The positive terminal has a male connector, and the negative terminal has a female connector. The connector used to connect the PV modules must be MC™ PV-KST3X (female) and PV-KBT3X(male) compatible with a rated current of 20A with a temperature rating of 90°C.
- 3) Limited by a maximum system voltage of 1000V, the number of modules that can be wired in series is recommended at eight (8) or fewer.
- 4) These modules contain factory installed bypass diodes. If these modules are incorrectly connected to each other, the bypass diodes, cable, or junction box may be damaged.
- 5) The number of modules or module strings in parallel can be as many as allowed by the inverter or the corresponding equipment to which the modules are connected. However, in practice care must be exercised to match Pmax and internal resistance for better performance and avoiding heating loss. Critical or undesirable operating conditions of a parallel connection of PV modules or strings can occur when modules are not closely matched in terms of their maximum power point voltages (resulting in mismatch losses), during partial shading of the parallel assembly, or under fault conditions. To

overcome the potential mismatch losses, it is strongly recommended to only combine modules of same technology, same manufacturer and with similar specifications in parallel

- 6) When combining a number of modules or modules strings in parallel, it is highly recommended to use a string fuse or circuit breaker in every string to limit reverse current. As in fault or partial shading situation a string becomes a “load” to the rest of the array and a reverse bias and current shall be applied to this string. The suggested fuse rating is chosen to be 2.5A.
- 7) In all cases, the conductor to be used should never have a cross-section less than 2.5 mm<sup>2</sup>. Should a larger cross-section be needed to transport the energy to the corresponding equipment, external junction boxes should be used, allowing connection of greater cable cross-sections.

## 6.1.1 Wiring tips

- 1) Do not cut cable attached to the PV module in order to connect to another type of connector or cable.
- 2) Connecting PV modules in series would increase voltage, and connecting in parallel would increase current. In order to design an adequate PV system, PV modules shall be connected in series and/or in parallel according to specifications of inverters or other DC loads.
- 3) While connecting several strings in parallel, it is necessary to keep equivalent quantity of PV modules to each parallel string. If connected incorrectly, PV modules will be damaged.
- 4) All system wiring shall be in accordance with local codes.

## 6.1.2 Series Wiring

PV modules can be wired in series to increase voltage. Connect cables from the positive (+) / negative (-) terminal of one module to the negative (-) / positive (+) terminal of the next module (Fig. 5).

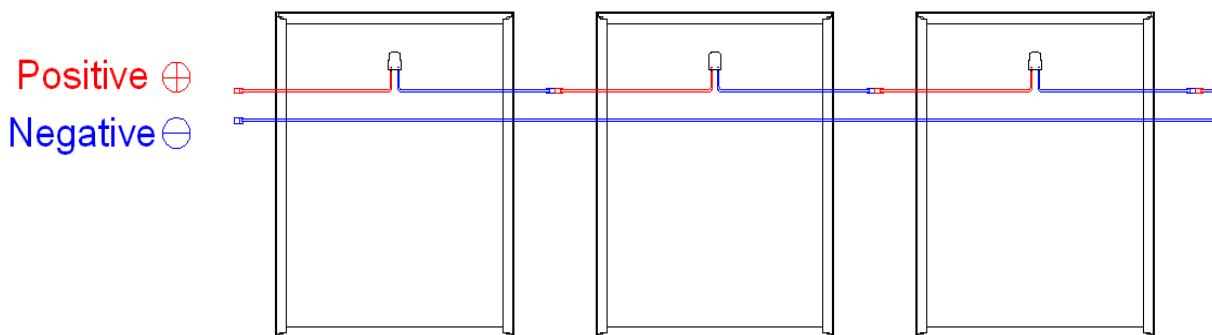

Fig. 5 Series connection

When several PV modules are connected in series, the voltage and current are as below:

$$V_{\text{total}} = V_1 + V_1 + \dots + V_n$$
$$I_{\text{total}} = I_1 = I_2 = \dots = I_n$$

n: number of PV modules in series

It is recommended to multiply the Voc listed on module label by a factor of 1.25, and make sure the system voltage must not exceed a maximum of 1000V, which in turn means that the number of modules in series shall never exceed six (6) for safety purposes.

### 6.1.3 Parallel Wiring

PV modules can be wired in parallel to increase current. Connect cables from the positive (+) / negative (-) terminal of one module to the positive (+) / negative (-) terminal of the next module (Fig. 6).

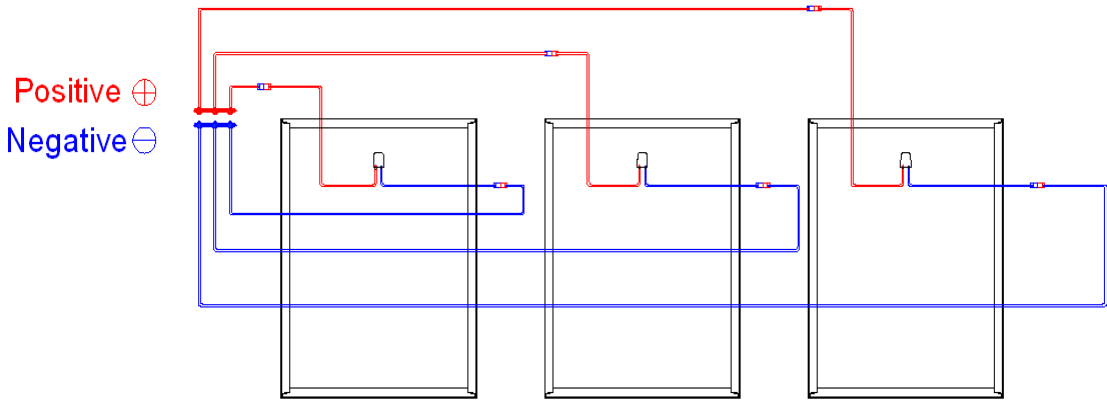

Fig. 6 Parallel connection

When several PV module strings are connected in parallel, the voltage and current are as below:

$$V_{total} = V_1 = V_2 = \dots = V_n$$

$$I_{total} = I_1 + I_2 + \dots + I_n$$

n: number of PV modules in parallel

Please be noted that the short-circuit current of system is calculated by multiplying the Isc listed on the module label by the number of source circuits operating in parallel. Use this value and multiply by 1.56 to determine the conductor capacities and fuse sizes connected to the module output.

### 6.1.4 Bypass Diode

When the modules in series strings are shaded partially, they may cause a reverse voltage across cells or modules, because the current from other cells in the same series is forced to flow through the shaded area, and then undesirable heating may occur. The use of a diode to bypass the shaded area can minimize both heating and reduction of array current. All ASF modules are equipped with factory installed bypass diodes, providing proper circuit protection for the systems within the specified system voltage, so that no additional bypass diodes shall be needed. The following summarize some data of the built-in diode in the module:

Item	Symbol	Conditions	Max. Rated Value	Unit
Repetitive Peak Reverse Voltage	$V_{RRV}$		1000	V
Average rectified Output Current	$I_0$	50Hz Full Sine Wave, 1 cycle, Non-repetitive	4	A
Operating Junction Temperature	$T_j$		-40~+190	°C
Peak Reverse Current	$I_{RV}$	$V_{RV}=1000V, T_j=25^{\circ}C$	Max 10	$\mu A$

## 6.2) Grounding

### 6.2.1 Grounding tips

- 1) Each PV module must be grounded with the grounding holes on the frames. The PV module has 8 of  $\Phi 3.5mm$  holes in its frame for grounding purpose (Fig. 7). Select at least one grounding hole according to PV module mounting mode.

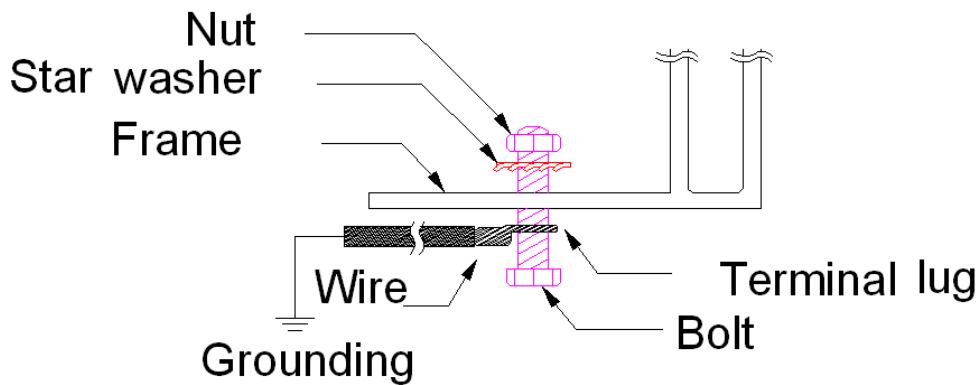

Fig. 7 Grounding connection structure

- 2) Must apply equipment grounding at the same electrical potential level to all PV modules.
- 3) Grounding cables must be bolted or screwed with star washers (Fig. 7).
- 4) The negative pole of solar generator strings connected to the inverter must also be grounded.

### 6.2.2 Grounding method

When connecting in series, PV modules either connect to structure members by attaching wires to the ground holes on the frames or directly bind with the structure member at adequate positions to deploy grounding method at designated equipment grounding spot. Grounding must be done on first or the last PV module of each string (Fig. 8).

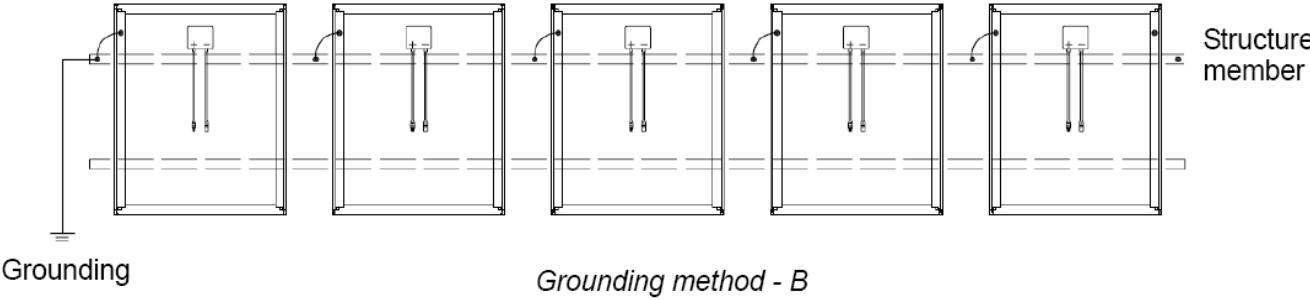
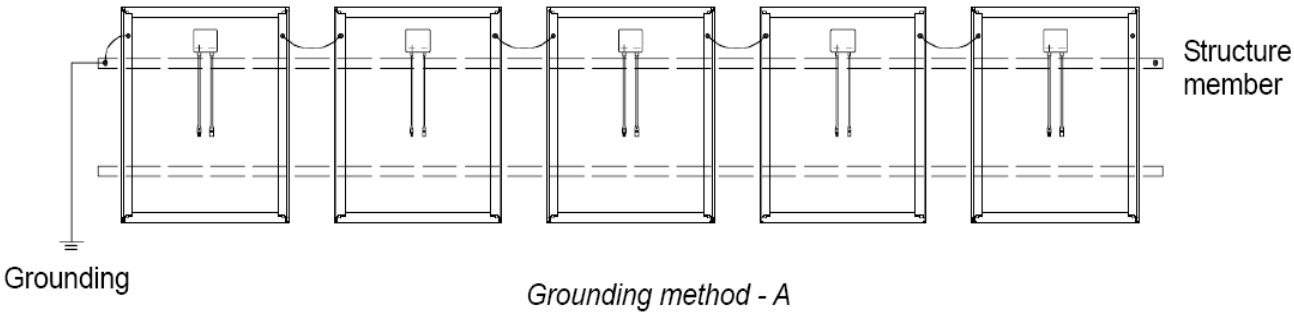

Fig. 8 Grounding method

**6.2.3 Connecting information**

- 1) Only connect series solar power modules of the same type and power rating.
- 2) It is not necessary to open the connector box with cables connected at the factory for electrical switching of the solar power modules!
- 3) The solar cables are equipped with the MC pin- and -socket connector for photovoltaic.
- 4) The plugs are marked with the respective polarity (see Illustration). The MINUS pole is minus-coded; the PLUS pole is plus-coded (Fig. 9).

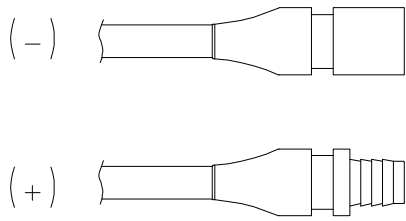

Fig. 9 MC connector

**Attention:**  
**Never disconnect or connect the pin-and-socket connections under electrical load!**

**7 INVERTER SELECTION**

To ensure warranty of AST ASF100 and ASF90 modules, it is essential to select

inverters with the following features.

- 1) Inverters with galvanic isolation (transformer type) and grounding on negative pole of solar generator strings; or,
- 2) Specifically designed transformer-less inverters which are characterized by negative pole grounding (e.g. Sunways AT series).

The warranty will be voided if failing to follow the above instructions.

For more detailed or specific recommendations, please contact your PV system dealer.

**Attention:**

**Not all inverters without transformers can be used. Please contact the manufacturer of the inverter for further information.**

## 8 MAINTENANCE

The PV modules are designed to last for extended period of time thus require very little maintenance.

When the dirt on the surface of PV module becomes excessively built-up, power output may decline consequently. When this situation occurs, cleaning module surface is necessary but only with a soft cloth and mild detergent water. Before washing, please wear electrical insulating gloves to avoid electrical accidents. Protect yourself against any possibility from accidents during maintenance. If cleaning the back of the module is required, take utmost care to avoid penetrating the back side materials. Check annually and carefully to ensure for fixed mounting hardware and tightened wiring. Any loose connections or parts will cause damages in modules or arrays. If any problem were found, please contact your local PV system dealer for the most professional services.

## 9 CERTIFICATES

The following certificates correspond to the module:

- Certificates of compliance, IEC/EN 61646 and IEC/EN 61730

Hangzhou AmpleSun Solar Technology Co., Ltd.

Add: #12 Road, Xiasha Export Processing Zone

Hangzhou 310018, P.R. China

Tel: +86-571-8691-1755

Fax: +86-571-8687-7288

Email: [sales@ample-sun.com](mailto:sales@ample-sun.com)

Website: <http://www.ample-sun.com>